

INSTALLATION, OPERATION AND MAINTENANCE INSTRUCTIONS

LOMOND E - Fluorescent Luminaires ATEX

Important: Please read these instructions carefully before installing or maintaining this equipment. Good electrical practices should be followed at all times and this data should be used as a guide only.



916 FOR 18W, 1516 FOR 36W, 1816 FOR 58W

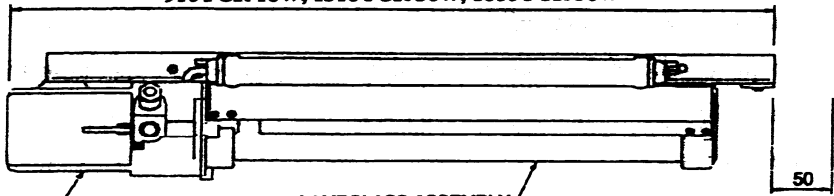

BALLAST HOUSING **LAMPGLASS ASSEMBLY** **50**

REQUIRED FOR THE REMOVAL OF THE LAMPGLASS ASSEMBLY

Luminaire	Gas Group	Temperature Classification	
		T6	T5
18W	IIB/IIIC	-20°C to +55°C	-20°C to +55°C
36W	IIB	-20°C to +55°C	-20°C to +55°C
58W	IIB	-20°C to +49°C	-20°C to +55°C

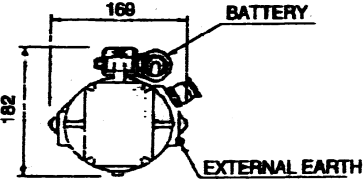

169 **BATTERY**
182 **EXTERNAL EARTH**

8W Model ONLY

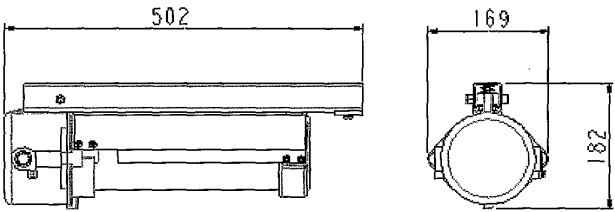

502 **169** **182**

LUMINAIRE	GAS GROUP	T6
8W	IIIC	- 20°C to +55°C

Type Of Protection	Ex de (flameproof and increased safety)
Protection Standards	EN 60079-0, EN 60079-1, EN 60079-7, EN 50281-1-1
Area Classification	Zone 1 and Zone 2 areas to EN 60079-10-1 Zone 21 and Zone 22 areas to EN 60079-10-2
Installation	EN 60079-14
Certificate	EC Type Examination Certificate Sira05ATEX1299X
Equipment Coding	Ex de IIB T5 / T6 T**°C (Tamb see Table 1)
ATEX Coding	Ⓔ II 2 GD T100°C or T85°C
Ingress Protection	IP66 to EN 60529
CE Mark	 <p>The CE marking of this product applies to "The Electrical Equipment (Safety) Regulations 2006", "The Electromagnetic Compatibility Regulations 2004", the "Waste Electrical and Electronic Equipment Regulations 2006" and the "Equipment and Protective Systems intended for use in Explosive Atmospheres Regulations 1996". [This legislation is the equivalent in UK law of EU directives 2014/35/EU, 2014/30/EU, 2012/19/EU and 2014/34/EU respectively].</p> <p>The Equipment is declared to meet the provisions of the ATEX directive (2014/34/EU) by reason of the EC Type Examination and compliance with the Essential Health and Safety Requirements. M Poutney Technical Manager</p>

SPECIAL CONDITIONS FOR SAFE USE

The Lomond and Lomond E ranges of luminaires shall only be installed in areas where there is a low risk of impact.

IMPORTANT

1. Read this leaflet carefully before commencing to install the luminaire and retain it for future reference.
2. Check the rating label to ensure that the luminaire is suitable for the supply provided.
3. The luminaire must be installed in accordance with the recognised code of practice e.g. EN60079-14.
4. High voltage insulation testing may be carried out, but the test voltage must not exceed 500V DC.
WARNING: Any faults to earth within the luminaires may result in permanent damage to the electronic control unit. This possibility can be avoided by shorting the live and neutral cables together and applying the test voltage between this connection and earth.
5. The luminaire **MUST** be earthed
6. The operating temperature range for the luminaire is shown on the rating label. The luminaire should not be used outside these temperatures.
7. If the luminaire is to be installed in areas of high vibration, please consult the manufacturer.
8. Under **NO** circumstances should a luminaire be opened, even when isolated, when an explosive gas or dust environment is present.
9. Battery pack is supplied disconnected, and should be re connected just prior to energising of fitting.
10. Storage of fitting with no mains power present, disconnect battery connections in a safe manner.
11. Battery packs in storage should be cycled charged/discharged/charged every 9 months, as per instructions below.
12. Any specific instructions concerning emergency luminaires must be complied with.
13. (Warning: Battery packs not cycled and stored for a year may not be recoverable)
14. Do not use excessive force on plastic components.
15. The luminaires are designed and constructed to EN60598.
16. Prices and design are subject to alteration without notice. All products are sold subject to our conditions of sale, copies of which are available on request. *We reserve the right to change characteristics of our products. All data is for guidance only.*

GENERAL INSTALLATION NOTES.

1. Do not attempt installation until you are familiar with all warnings, precautions and procedures within this instruction sheet.
2. Refer to the wiring diagrams for correct installation.
3. Do not over tighten fasteners into plastic parts.
4. Ensure that the mains cable connectors are correctly secured to the terminal block(s). Only one conductor should be fitted to each terminal block. All terminal screws should be fully tightened whether a conductor is fitted or not.
5. Blanking plugs and cable glands must be of the correct type and must be fitted to the manufacturer's specification to ensure that the seals prevent the ingress of moisture or dust and so maintain the luminaire's IP rating.

**GENERAL MAINTENANCE NOTES.**

- IMPORTANT.** Isolate the luminaire from both switched and unswitched mains supplies before carrying out any maintenance work.
- Lamps must be changed at the intervals recommended by the lamp manufacturer.
- It is essential that all luminaires together with their associated cables, glands, etc. which make up the installation are maintained in such a manner as to ensure the integrity of the protection to which it is designed.
- The frequency of inspection must be determined by the user, but should be regular enough to ensure that the luminaire installation continues to operate in the designed manner. The more onerous the operating conditions, the more frequent the inspections should be. It is recommended that the interval between inspections should not exceed two years.
- Plastic components may be cleaned with water containing a small amount of detergent, followed by a clean water wash. Surplus water can be wiped off plastic components, but they should not be wiped or polished with a dry cloth to avoid a build up of static electricity.
- IMPORTANT.** All components that are replaced must be in accordance with the manufacturer's specification. Failure to use such components invalidates the certification, approval and warranty of the luminaire and may make it dangerous. NO modification should be made to the luminaire without the knowledge and approval of the manufacturer. If in doubt, refer to the manufacturer.

Model	Length (feet)	Certification Code
8W	1	Ex de IIB T6 Ta -20°C to +55°C or Ex de IIC T6 Ta -20°C to +55°C
18W	2	Ex de IIB T6 Ta -20°C to +55°C or Ex de IIC T6 Ta -20°C to +55°C
36W	4	Ex de IIB T6 Ta -20°C to +52°C or Ex de IIB T5 Ta -20°C to +55°C
58W	5	Ex de IIB T6 Ta -20°C to +48°C or Ex de IIB T5 Ta -20°C to +55°C

TECHNICAL DATA

Total circuit watts: 1 x 8 = 10W , 2x18W= 38W, 2x36W=68W, 2x58W=110W
 Maximum inrush current at switch on is 20A (8W), 30A (18W), 40A (36W) and 45A(58W) for < 1ms
 Power factor correction is better than 0.95
 Only T8 lamps should be used.
 The luminaire is made from aluminium (body), glass (lens), stainless steel (reflector) and galvanised steel (mounting channel).
 The user must ensure that these materials are suitable for the atmosphere the luminaire will be installed in.

SPECIAL NOTES

Please consult the manufacturer if the luminaire is to be used in high vibration areas.
 The luminaire is only suitable for use in areas with low impact risk.
 NO ATTEMPT must be made to remove the reflector from the lampglass assembly.
 The glass assembly should be kept clean.
 The terminal block is suitable for cables from 0.5mm² to 4mm². An external and internal earth is provided.
 The luminaire may be operated maintained, non-maintained or switched. When operating in the switched mode an Ls supply will be required.

INSTALLATION AND MAINTENANCE NOTES SPECIFIC TO THIS PRODUCT.

The lampglass assembly must be removed prior to mounting the luminaire. This achieved by removing the spring nut/square washer at the end of the channel, releasing the two screws connecting the assembly to the ballast housing and unclipping the suspension cable. The mounting channel should be secured in any orientation using a minimum of two fixing points. The luminaire should then be reassembled with lamps fitted, as described below. Fit the spring nut/ square washer in the undercut in the lampglass end casting to prevent movement due to vibration.
 Two M20 cable entry points are provided for fitting approved flameproof cable entry devices, with or without the use of approved flameproof thread adaptors. Care should be taken to ensure sealing of the glands is adequate to maintain the IP66/67 integrity.

GENERAL MAINTENANCE

- Flamepaths should be checked periodically for damage or corrosion.
- Flamepaths should be cleaned using a non-metallic scraper and/or suitable non-corrosive cleaning fluids.
- Cracked or broken lampglass assemblies must be replaced by units supplied by the manufacturer.
- Replace any missing fasteners with items of the correct quality
- The lampglass assembly should be kept clean. (Solvents should not be used in the cleaning process.)
- Parts that are cracked, damaged or worn must be replaced with the correct parts supplied by the manufacturer.

LAMPING AND RELAMPING

- Remove the lampglass assembly as described above. The lampglass should be jacked out as the screws are progressively slackened, if not jar the ballast housing slightly to free it. Allow the lampglass to hang on the suspension cord.
- Disconnect the plug and socket connection to the geartray. Slacken the geartray securing screw to allow the geartray to be withdrawn.

3. The lamps can be fitted by locating their pins in the lampholders and rotating them through 90°. The geartray assembly can then be installed in the lampglass assembly by reversing the above process.
4. Apply a smear of non-setting grease to the flamepath on the lampglass assembly before fitting it to the ballast housing. These two parts should be aligned carefully and the bolts should tighten without difficulty. If not, attempt to improve the alignment.
5. Secure the assembly by alternately tightening the securing screws. Some resistance may be encountered because of air locking of the enclosure. The assembly is completed when the lampglass assembly is fully home and compressing the sealing ring.

BATTERY MAINTENANCE

Before starting work pay attention to IMPORTANT note 8 above.

Isolate the unit from the mains. To remove the battery assembly, first remove the lampglass assembly as described above. Loosen the two screws holding the battery tube brackets to the channel bar. Inside the ballast housing, separate the battery connections (red and black bullet connectors). Remove the M20 flameproof cable gland on the battery cable and pull the battery cable through.

The battery may be only be removed from its mounting tube away from the hazardous area. The process is as follows:- Carefully withdraw the end moulding from the battery tube ensuring that the internal wiring is not stressed. . (A slight rotation, a few degrees either way, can help removal. Do not twist in one direction only as the wires may become damaged, short circuit the battery and blow it's fuse.) Disconnect the battery wires one at a time by inserting a screwdriver through the holes in the side of the moulding. As each wire is removed it should be insulated. Failure to do this may result in a short circuit.

The battery may now be removed from the tube. Do not use the leads to aid removal. When replacing a battery ensure that the sponge rubber strips are inserted around the inside of the tube.

If the battery is to be checked separately, it should be charged using a **constant current charger** at 200/400mA for 30/15 hours for the 4Ah (18W or 36W) Discharge measurement is not easy as the current is proportional to the voltage for resistance loads, so it has to be averaged. Discharge the battery at 1 to 2A and multiply current by time. Do not discharge below 1 volt per cell, which is 5V. The capacity should be 75% or more of normal.

REPLACING THE FUSE ASSEMBLY.

Remove the battery tube as described above and carry to a safe area.

The fuse assembly is located at the opposite end of the battery tube to the cable. To replace it, remove the two fixing screws securing the bracket and end moulding and remove the end moulding, observing the same precautions mentioned above for battery replacement. The battery fuse is then exposed. (The '+' and '-' markings on the moulding do not apply at the effuse end and can therefore be ignored. Remove the solder connected receptacles from each terminal blade of the fuse assembly. When replacing the fuse assembly the receptacles on the battery wires must be pushed on to the terminal blades and soldered to provide the approved connection. When inserting the fuse assembly into the end moulding ensure that the flat sides are positioned along the flat sides of the end moulding.

HEALTH AND SAFETY AT WORK etc. ACT 1974

In the United Kingdom all equipment must be installed, operated and disposed of (as required) within the legislative requirements of the Health and Safety at Work etc. Act 1974. Leaflet No. HSS L1 refers to the Company's obligation and is available on request.

It is the responsibility of the user to select, install, operate and maintain the equipment in accordance with the relevant legislation and appropriate codes of practice.

Disposal of Material

Any disposal must satisfy the requirements of the WEEE directive [2012/19/EU] and therefore must not be treated as commercial waste. The unit is mainly made from incombustible materials. The control gear contains plastic, resin and electronic components. All electrical components may give off noxious fumes if incinerated.

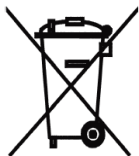

To comply with the Waste Electrical and Electronic Equipment directive 2012/19/EU the apparatus cannot be classified as commercial waste and as such must be disposed of or recycled in such a manner as to reduce the environmental impact.

TYPICAL WIRING DIAGRAMS

2 x 18/36/58 WATT

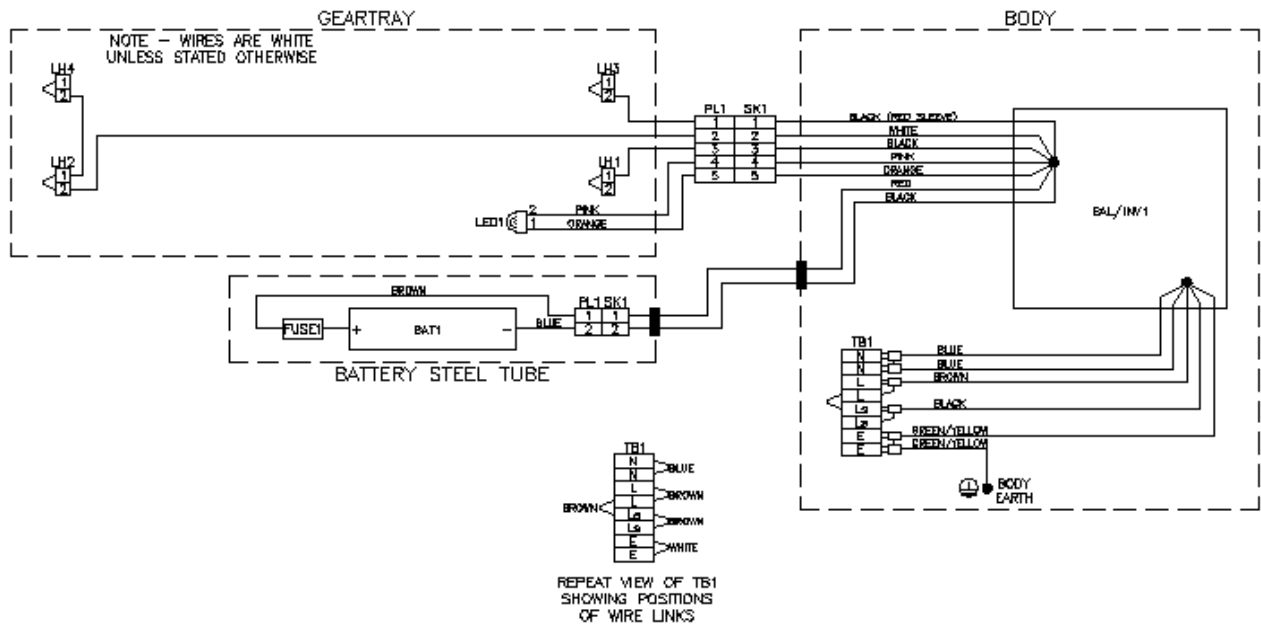

1 x 8 WATT

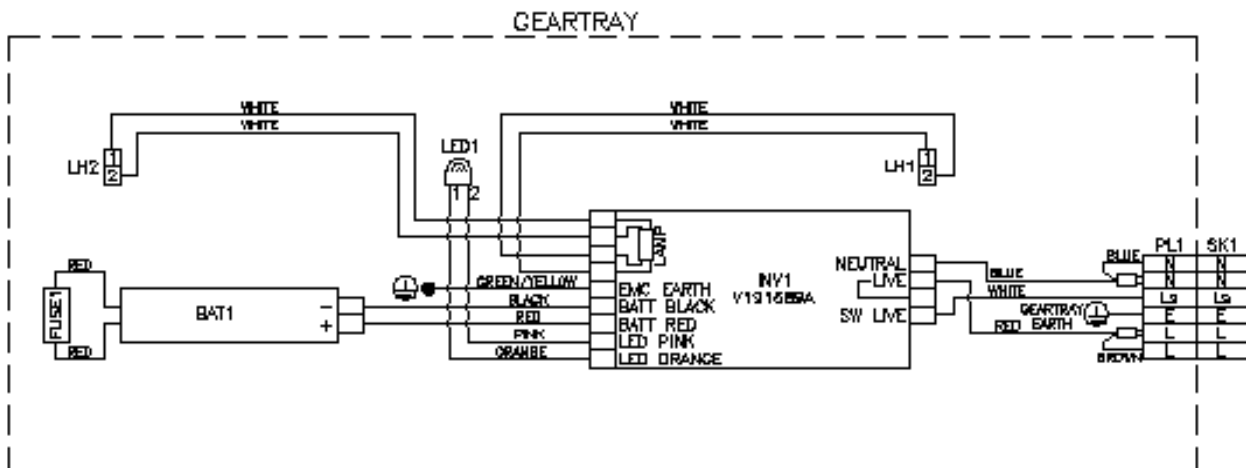





Chalmit Lighting is a leading supplier of Hazardous Area lighting products

	CHALMIT LIGHTING PO Box 5575 Glasgow, G52 9AP Scotland	
Telephone: +44 (0) 141 882 5555 Fax: +44 (0) 141 883 3704 Email: info@chalmit.com Web: www.chalmit.com	Registered No: 669157 Registered Office: Cannon Place 78 Cannon Street London EC4N 6AF UK	

For technical support, please contact: techsupport@chalmit.com

Note: Chalmit Lighting reserves the right to amend characteristics of our products and all data is for guidance only.

	EU-Declaration of conformity		
	UE-Déclaration de conformité		
	EU-Konformitätserklärung		
Manufacturer	Chalmit	Address	388 Hillington Road, Glasgow. G52 4BL Scotland UK
Product	Lomond E Luminaire. (Emergency).		
EC - Type Examination Certificate	Sira05ATEX1299X		
Notified Body	CSA Group Netherlands B.V. 2813		
ATEX Coding	 II 2 GD	ATEX Classification	Group II Category 2 GD
Equipment Coding	Ex de IIB T6 / T5 or (IIC T6) T100°C or T85°C		
Ingress Protection	IP66/67		
The technical basis, with respect to equivalence of			
La base technique, en ce qui concerne l'équivalence de			
Die technische Grundlage hinsichtlich der Normen			
Protection Standards EN 60079-0, EN 60079-1, EN 60079-7, EN 50281-1-1			
Area Classification EN 60079-10-1 and EN 60079-10-2			
of compliance with the EHSRs is valid as there are no changes which materially affect the state of technological progress of the product.			
en conformité avec les EESS est valide puisqu'il n'y a aucun changement qui affecte matériellement l'état de l'évolution technologique du produit.			
zur Erfüllung der GSGA ist gegeben, da keine Änderungen erfolgt sind, die einen Einfluss auf den technischen Stand des Produkts haben.			
Terms of the directive:		Standard & Date Certified to	Standards Date Declared to
Prescription de la directive:		Standard & date certifiée à	Normes date Déclaré
Bestimmungen der Richtlinie:		Standard & Datum Zertifiziert nach	Standards Datum erklärt
2014/34/EU	Equipment and protective systems intended for use in potentially explosive atmospheres.	EN 60079-0: 2004	2012
		EN 60079-1: 2004	2014
2014/34/UE	Appareils et les systèmes de protection destinés à être utilisés en atmosphères potentiellement explosibles.	EN 60079-7: 2003	2015
		EN 50281-1-1: 1999	2014
2014/34/EU	Geräte und Schutzsysteme zur bestimmungsgemäßen Verwendung in explosionsfähigen Bereichen.		
2014/30/EU	Electromagnetic compatibility	EN 55015 : 2013	
2014/30/UE	Compatibilité électromagnétique	EN 61547 : 2009	
2014/30/EU	Elektromagnetische Verträglichkeit	EN 61000-3-2 : 2014	
2014/35/EU	Low voltage equipment	EN 60598-1 : 2015	
2014/35/UE	Équipements électriques à bas voltage	EN 60598-2-5 : 2015	
2014/35/EU	Niederspannungsgeräte / -systeme	EN 60598-2-22: 2014	
		EN 60529 : 1992	
2012/19/EU	Waste of electrical and electronic equipment		
2012/19/UE	Déchets d'équipements électriques et électroniques		
2012/19/EU	Entsorgung der elektrischen und elektronischen Geräte / Systeme		
2011/65/EU	RoHS II Directive		

IOM – LOMOND E- ZONE 1 FLAMEPROOF EMERGENCY FLUORESCENT (ATEX)

On behalf of the Chalmit, I declare that, on the date the equipment accompanied by this declaration is placed on the market, the equipment conforms to all technical and regulatory requirements of the above listed directives.

En tant que représentant du fabricant Chalmit, je déclare qu'à la date où les équipements accompagnant cette déclaration sont mis sur le marché, ceux-ci sont conformes à toutes les dispositions réglementaires et techniques des directives énumérées ci-dessus.

Hiermit bestätige ich, im Namen von Chalmit, dass am Tag der Lieferung des Produkts/der Produkte zusammen mit dieser Erklärung das Gerät/die Geräte alle technischen und regulativen Anforderungen der oben aufgeführten Direktiven erfüllt.

Name and Date Mark Poutney 01/01/2021
Nom et Date
Name und Datum

Technical Manager
Directeur technique
Technischer Leiter



Quality Assurance Notification by: **SGS FIMKO OY**
Notification d'assurance qualité par: **0598**
Qualitätssicherungsnotifikation durch:

Quality Management System Accreditation:
Système de Management Qualité Accréditation:
Qualitätsmanagementsystem Akkreditierung:
Environmental Management System.
Système de gestion de l'environnement.
Umwelt kontroll system.
Certificate No./Certificat N°/Zertifikat Nr.

ISO 9001

ISO 14001
by/par/durch
Loyd's Register
LRQ 4005876